

Adaptive Observer of Magnetic Flux for a Nonsalient-pole Permanent Magnet Synchronous Motor

Polina Noskova
 ITMO University
 Saint-Petersburg, Russia
 polynar@yandex.ru

Rami Al-Naim
 ITMO University
 Saint-Petersburg, Russia
 rami.naim2010@yandex.ru

Abstract—In this paper a new algorithm for the synthesis of a magnetic flux observer for a nonsalient-pole permanent magnet synchronous motor is presented. The following assumptions are made: some electrical parameters of the motor (the resistance and inductance of the stator) are known and constant, the current and voltage of motor are measurable. The proposed approach to observer synthesis is based on the use of trigonometric properties and linear filtering properties that allow to conduct a standard regression model consisting of measurable time-varying functions and unknown components of the magnetic flux. It is proved that the proposed observer provides global exponential convergence of estimation errors to zero. To verify the correct operation of the obtained observer simulation is performed in the MATLAB environment for various load moments of the motor.

I. INTRODUCTION

At this stage of technology development, interest in sensorless vector control is growing more and more [1]. First of all, such an approach to solve control problems is considered effective for systems whose operating conditions or design features do not allow the use of state sensors [2]. The use of observer synthesis algorithms for other technical systems is due to the fact that the cost of the sensors is very high and comparable with the cost of the control object itself [3]. The economic benefits of using observers are especially evident in mass production or when the number of measuring devices is limited [2], [3].

One of the most common motors used in industry is a permanent magnet synchronous motor (PMSM). Modern observer synthesis algorithms for sensorless control of PMSMs are often based on the gradient descent and the dynamic regressor extension methods [4]–[7]. These approaches often have good accuracy characteristics over the entire range of operating velocities. However, both of these methods are based on the integration of current and voltage signals that are noised in real systems [8], [9].

Thus, measurement errors of these variables accumulate and lead to a deterioration in the accuracy of the observer. In this paper, a new method for synthesis an adaptive observer of magnetic flux for PMSM is proposed.

In this paper, we propose a new method for synthesizing an adaptive observer of magnetic flux for PMSM that does not use the integration of noised signals.

The rest of the paper is organized as follows. In Section II we describe the state-of-the-art of the search of solution for the aforementioned problem. The Section III provides the formal statement of the observer synthesis problem. In the Section IV the description of the observer is given. In the Section V the obtained observer is tested in the MATLAB environment simulation. Conclusions are summarized in the last section.

II. OVERVIEW OF SENSORLESS CONTROL AND EXISTING SOLUTIONS

The block diagram of the sensorless control of a synchronous motor using an observer in a simplified form is presented in the Fig. 1.

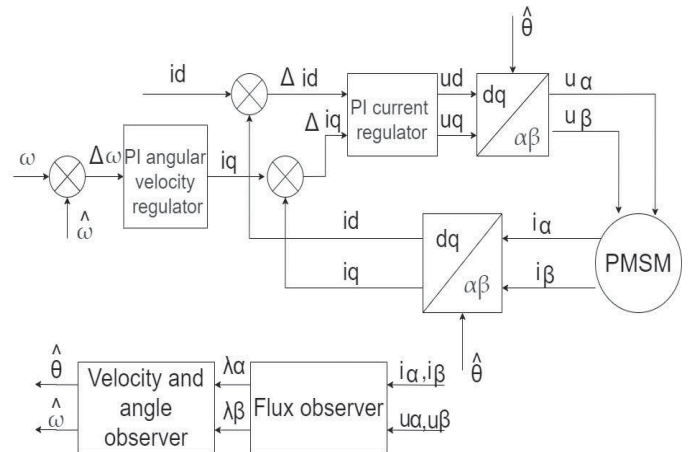

Fig. 1. PMSM sensorless control block diagram: $i_\alpha, i_\beta, i_d, i_q$ — current components in $\alpha\beta$ and dq coordinates; $u_\alpha, u_\beta, u_d, u_q$ — voltage components in $\alpha\beta$ and dq coordinates; ω — desired rotor velocity; $\hat{\omega}, \hat{\theta}$ — estimations of rotor velocity and angle; $\lambda_\alpha, \lambda_\beta$ — estimations of the magnetic flux components in $\alpha\beta$ coordinates

To synthesize a magnetic flux observer, a description of the control object in $\alpha\beta$ coordinates is used. The motor is controlled using two PI controllers, the input of which receives the difference between the desired and estimated angular velocity and the difference between the desired and actual current value in the dq coordinate system. Such control scheme contains two control loops. The d loop is responsible for regulating the total magnetic flux and the desired current value $i_d = 0$. The q loop controls motor velocity. As a result,

at the output of the second regulator a reference-input signal is generated for the motor which is the voltage vector in the dq system [10].

For the converting between $\alpha\beta$ and dq coordinate systems, the direct and inverse Park transformation are used [11]. They are described by the equations:

$$\begin{aligned} u_\alpha &= u_d \cos(\theta) - u_q \sin(\theta), \\ u_\beta &= u_d \sin(\theta) + u_q \cos(\theta), \\ i_d &= i_\alpha \cos(\theta) + i_\beta \sin(\theta), \\ i_q &= -i_\alpha \sin(\theta) + i_\beta \cos(\theta). \end{aligned}$$

The estimation of unknown parameters is carried out in two stages. At the first stage, the magnetic flux vector of the motor is estimated, which input signals are current and voltage. At the second stage, from the obtained estimations of the magnetic flux, estimations of the angular velocity and the angle of rotation can be obtained.

For the synthesis of magnetic flux observers, various methods for conducting a regression model are proposed.

In paper [12], an observer synthesis algorithm that uses the dynamic regressor extension and mixing (DREM) method is presented. The main idea of the algorithm is that a dynamic operator is applied to the original regression model. This operator allows to expand the existing regressor and get two linearly independent equations. This approach allows to reduce the estimation error the stator magnetic flux. However, during the conducting of the regression model, the current and voltage signals are integrated, which leads to the accumulation of measurement error of these signals. This leads to a decrease in the accuracy of estimation the magnetic flux when using this approach to control a real motor.

In paper [13], a different approach of sensorless motor control is used. In the section describing the observer of the magnetic flux, a regression model described as a non-decreasing function is conducted to estimate the initial conditions of the magnetic flux. During the simulation, the authors show that the observer also works under the condition of using the velocity calculated on the basis of the estimated magnetic flux. However, the regression model includes integrated values of current and voltage signals, which also reduces the accuracy of estimation the magnetic flux, and, as a result, the efficiency of sensorless motor control.

III. PROBLEM STATEMENT

The model of a nonsalient-pole permanent magnet synchronous motor in a stationary $\alpha\beta$ system is described by a system of equations:

$$\dot{\lambda} = u - Ri, \quad (1)$$

$$\lambda = Li + \lambda_m \cdot C(\theta), \quad (2)$$

where $\lambda = [\lambda_\alpha, \lambda_\beta]^T$ — stator magnetic flux; $i = [i_\alpha, i_\beta]^T$ — electric current; $u = [u_\alpha, u_\beta]^T$ — voltage; L and R — known inductance and resistance of stator; λ_m — magnetic flux of permanent magnets; θ — electromagnetic angle; matrix $C(\theta)$ of the following form:

$$C(\theta) = \begin{bmatrix} \cos(\theta) \\ \sin(\theta) \end{bmatrix}.$$

The task is to synthesize an observer of an unknown magnetic flux vector λ and to ensure the exponential convergence of the error to zero.

IV. PROPOSED MAGNETIC FLUX OBSERVER

Before deriving the linear regression formula for magnetic flux, it is necessary to consider the following lemma.

Lemma 1 (Swapping lemma [14]): Suppose that f_1 and f_2 are differentiable and $f_1, f_2 : \mathbb{R} \rightarrow \mathbb{R}$. Then the following identity holds for them:

$$\frac{\alpha}{p+\alpha}(f_1 f_2) = \left(\frac{\alpha}{p+\alpha} f_1\right) f_2 - \frac{\alpha}{p+\alpha} \left\{ \left(\frac{\alpha}{p+\alpha} f_1\right) \dot{f}_2 \right\},$$

where α is a positive real constant, $p = \frac{d}{dt}$.

Later in the text subscripts 1 and 2 will be used for projections of variables on α and β axes. We decompose the equation (2) into two phases and square both equations. Then we sum up the resulting expressions and apply the Pythagorean trigonometric identity. The result of applying these operations takes the form:

$$\begin{cases} \lambda_1^2 = L^2 i_1^2 + \lambda_m^2 \cos^2(\theta), \\ \lambda_2^2 = L^2 i_2^2 + \lambda_m^2 \sin^2(\theta), \end{cases}$$

$$\lambda_m^2 (\cos^2(\theta) + \sin^2(\theta)) = \lambda_1^2 + \lambda_2^2 - 2L(\lambda_1 i_1 + \lambda_2 i_2) + L^2(i_1^2 + i_2^2),$$

$$\lambda_m^2 = \lambda_1^2 + \lambda_2^2 - 2L(\lambda_1 i_1 + \lambda_2 i_2) + L^2(i_1^2 + i_2^2). \quad (3)$$

Apply a first-order filter to the expression (3):

$$\begin{aligned} \lambda_m^2 &= \frac{\alpha}{p+\alpha} \lambda_1^2 + \frac{\alpha}{p+\alpha} \lambda_2^2 - \\ &- 2L \left(\frac{\alpha}{p+\alpha} \lambda_1 i_1 + \frac{\alpha}{p+\alpha} \lambda_2 i_2 \right) + \\ &+ L^2 \left(\frac{\alpha}{p+\alpha} i_1^2 + \frac{\alpha}{p+\alpha} i_2^2 \right). \end{aligned} \quad (4)$$

Term λ_m in (4) is not affected by first-order filter since it is a constant value. Using Lemma 1 the addends on the right-hand side of the expression (4) are transformed to:

$$\begin{aligned} \frac{\alpha}{p+\alpha} \lambda^2 &= \lambda \frac{\alpha}{p+\alpha} \lambda - \frac{\alpha}{p+\alpha} \left\{ \dot{\lambda} \frac{\alpha}{p+\alpha} \lambda \right\} = \\ &= \lambda \left(\lambda - \frac{\alpha}{p+\alpha} \dot{\lambda} \right) - \frac{\alpha}{p+\alpha} \left\{ \dot{\lambda} \left(\lambda - \frac{\alpha}{p+\alpha} \dot{\lambda} \right) \right\} = \\ &= \lambda^2 - \lambda \dot{\phi} - \frac{\alpha}{p+\alpha} \dot{\lambda} \lambda + \frac{\alpha}{p+\alpha} \dot{\lambda} \phi, \end{aligned} \quad (5)$$

where $\phi = \frac{\alpha}{p+\alpha} \dot{\lambda}$.

$$\frac{\alpha}{p+\alpha}\lambda i = \lambda \frac{\alpha}{p+\alpha}i - \frac{\alpha}{p+\alpha}\left\{\dot{\lambda} \frac{\alpha}{p+\alpha}i\right\} = \gamma\lambda - \beta, \quad (6)$$

$$\text{where } \gamma = \frac{\alpha}{p+\alpha}i, \beta = \frac{\alpha}{p+\alpha}\left\{\dot{\lambda} \frac{\alpha}{p+\alpha}i\right\}.$$

Equate expressions (3) and (4) given the expressions (5) and (6):

$$\begin{aligned} & -2L(\lambda_1 i_1 + \lambda_2 i_2) + L^2(i_1^2 + i_2^2) = \\ & = -\lambda_1 \phi_1 - \lambda_2 \phi_2 - \frac{\alpha}{p+\alpha}\dot{\lambda}_1 \lambda_1 - \frac{\alpha}{p+\alpha}\dot{\lambda}_2 \lambda_2 + \\ & + \frac{\alpha}{p+\alpha}\dot{\lambda}_1 \phi_1 + \frac{\alpha}{p+\alpha}\dot{\lambda}_2 \phi_2 - 2L\gamma_1 \lambda_1 - \\ & - 2L\gamma_2 \lambda_2 + 2L\beta_1 + 2L\beta_2 + \rho_1 + \rho_2, \end{aligned} \quad (7)$$

$$\text{where } \rho = L^2 \frac{\alpha}{p+\alpha} i^2.$$

Using Lemma 1 the addends on the right-hand side of the expression (7) are transformed to:

$$\frac{\alpha}{p+\alpha}\dot{\lambda}\lambda = \lambda \frac{\alpha}{p+\alpha}\dot{\lambda} - \frac{\alpha}{p+\alpha}\left\{\dot{\lambda} \frac{\alpha}{p+\alpha}\lambda\right\} = \lambda\phi - z, \quad (8)$$

$$\text{where } z = \frac{\alpha}{p+\alpha}\dot{\lambda}\phi.$$

Substituting the expression (8) into (7) we get:

$$\begin{aligned} & -2L(\lambda_1 i_1 + \lambda_2 i_2) + L^2(i_1^2 + i_2^2) = \\ & = -2\lambda_1 \phi_1 + 2z_1 - 2\lambda_2 \phi_2 + 2z_2 - 2L\gamma_1 \lambda_1 - \\ & - 2L\gamma_2 \lambda_2 + 2L\beta_1 + 2L\beta_2 + \rho_1 + \rho_2. \end{aligned}$$

To conduct a regression model, we move on to a system of equations of the form:

$$\begin{cases} \psi_1 = g_1 \lambda_1, \\ \psi_2 = g_2 \lambda_2, \\ 2z_1 - L^2 i_1^2 + 2L\beta_1 + \rho_1 = (2\phi_1 - 2Li_1)\lambda_1 + 2L\gamma_1, \\ 2z_2 - L^2 i_2^2 + 2L\beta_2 + \rho_2 = (2\phi_2 - 2Li_2)\lambda_2 + 2L\gamma_2. \end{cases}$$

From the resulting system we obtain the required functions g and ψ :

$$\begin{aligned} \psi_1 &= 2z_1 - L^2 i_1^2 + 2L\beta_1 + \rho_1, \\ \psi_2 &= 2z_2 - L^2 i_2^2 + 2L\beta_2 + \rho_2, \\ g_1 &= 2\phi_1 - 2Li_1 + 2L\gamma_1, \\ g_2 &= 2\phi_2 - 2Li_2 + 2L\gamma_2. \end{aligned}$$

The observer of magnetic flux is synthesized in the form of a differential equation:

$$\dot{\hat{\lambda}} = -Ri + u - kg^2 \hat{\lambda} + kg\psi, \quad (9)$$

where $\hat{\lambda}$ — magnetic flux estimation; k — adaptation coefficient.

Let us prove the convergence of the estimation error to zero. The estimation error the first component of the magnetic flux is expressed as:

$$\tilde{\lambda}_1 = \hat{\lambda}_1 - \lambda_1. \quad (10)$$

After differentiating expression (10) and substituting the values of the derivatives of magnetic flux (1) and its estimation (9) we obtain:

$$\dot{\tilde{\lambda}}_1 = \dot{\hat{\lambda}}_1 - \dot{\lambda}_1 = -k_1 g_1^2 \hat{\lambda}_1 + k_1 g_1 \psi_1. \quad (11)$$

Let's substitute the value of the function ψ_1 into the expression (11):

$$\dot{\tilde{\lambda}}_1 = -k_1 g_1^2 \hat{\lambda}_1 + k_1 g_1^2 \lambda_1 = -k_1 g_1^2 \tilde{\lambda}_1 \quad (12)$$

As a result, we obtain the standard differential equation for the estimation error of the magnetic flux with the following solution:

$$\tilde{\lambda}_1 = \tilde{\lambda}_1(0)e^{-k_1 \int_0^t g^2 dt}$$

If function g is quadratic integrable and follows the persistency of excitation condition, estimation error of the magnetic flux converges to zero:

$$\lim_{t \rightarrow \infty} \tilde{\lambda}_1 = 0$$

Similarly, the convergence of the estimation error for the second component of the magnetic flux is proved.

To organize motor control through an observer, we introduce estimation of rotation velocity and the angle of rotation of the PMSM rotor. An estimation of the angular position $\hat{\theta}_r$ can be obtained through the estimation of the magnetic flux:

$$\hat{\theta}_r = \frac{1}{n_p} \arctan \left\{ \frac{\hat{\lambda}_2 - Li_2}{\hat{\lambda}_1 - Li_1} \right\},$$

where n_p — number of poles.

The rotor velocity estimation can be obtained by adding a PI controller, the input of which receives the estimated angle [15].

V. VERIFICATION OF THE SYNTHESIZED OBSERVER

To test the performance and estimate the accuracy of the resulting observer, simulation was performed in MATLAB environment for various values of the loads. The parameters of the tested motor are shown in Table I.

TABLE I. THE PARAMETERS OF MOTOR

Stator resistance, R	8.875 Ω
Stator inductance, L	40.3 mH
Permanent magnet flux, λ_m	0.2086 Wb
Number of pole pairs, n_p	5
Moment of inertia, J	$60 \cdot 10^{-6}$ kg m ²

Simulation was carried out in two stages (see Table II). In the first stage, the observer was checked in the passive mode, when the angle and velocity of rotation were being obtained from the rotor.

TABLE II. EXPERIMENTS CONDITIONS

Experiment number	1	2	3	4
Control via observer	-	-	+	+
Presence of load moment	-	+	-	+

For the case without load moments on the motor shaft and adaptation and filtering coefficients equal to 1, transient responses were obtained, which are presented in Fig. 2.

Then the observer was tested for a nonzero load moment $\tau_L = 0.5$ N.m. In order to decrease the response time of system and improve the nature of transient response, the adaptation coefficients were taken equal $\alpha = 1.3$, $k = 150$. The simulation results are shown in the Fig. 3.

In the second stage, control was carried out according to data from the observer, velocity and angle sensors were absent. The simulation was carried out for cases similar to those that were done in the first stage. The simulation results are shown in Fig. 4 and 7. Also, to demonstrate the correctness of the observer's work, graphs of the estimation errors of the velocity (Fig. 5 and 8) and rotation angle (Fig. 6 and 9) were obtained.

As can be seen from the graphs, the observer ensures the convergence of the estimation errors of the magnetic flux, velocity and angle of rotation for all simulation cases. In the presence of a load the estimation error of the magnetic flux converges to zero for a sufficiently long time, fluctuating around close values.

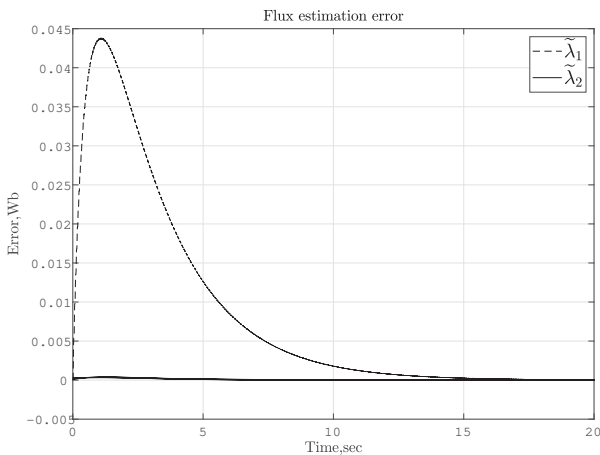

Fig. 2. Graph of the estimation error of the magnetic flux without load moment

VI. TESTING THE ALGORITHM ON REAL MOTOR DATA

To verify the operability of the algorithm in real conditions, modeling was performed based on data taken from the ESTUN EMG-10ASA22 motor. The parameters required for the observer are presented in Table III.

TABLE III. THE PARAMETERS OF ESTUN EMG-10ASA22 MOTOR

Stator resistance, R	2.5 Ω
Stator inductance, L	7.25 mH
Number of pole pairs, n_p	4

Known signals are stator currents and voltages which were translated into $\alpha - \beta$ coordinate system. They are shown in the Fig. 10 and 11. An angle of rotation of the rotor was also obtained in order to compare it with the value of the estimation of angle obtained by the observer (Fig. 12).

It can be seen (Fig. 13) that the error in the angle of rotation is significantly small. We can state that the observer synthesized in Section 4 shows good results under real operating conditions.

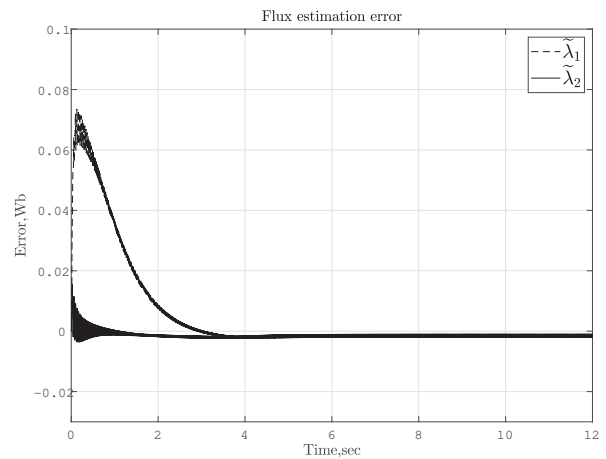

Fig. 3. Graph of the estimation error of the magnetic flux with load moment

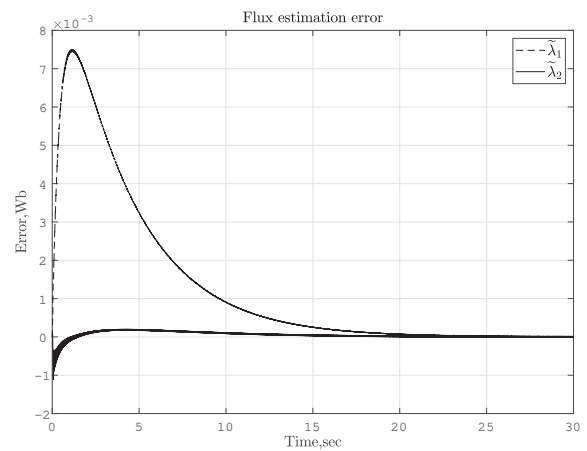

Fig. 4. Graph of the estimation error of magnetic flux without load moment and control through the observer

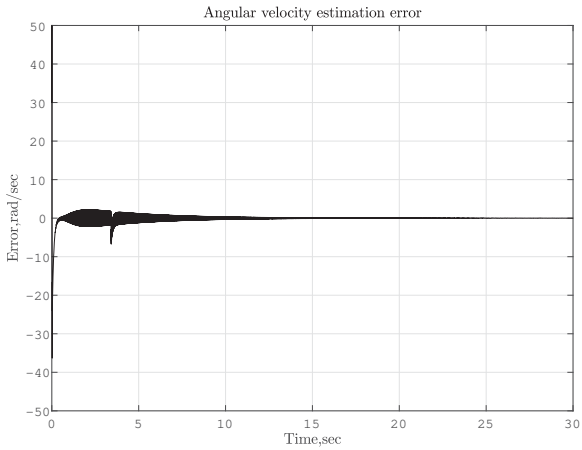

Fig. 5. Graph of the estimation error of velocity without load moment and control through the observer

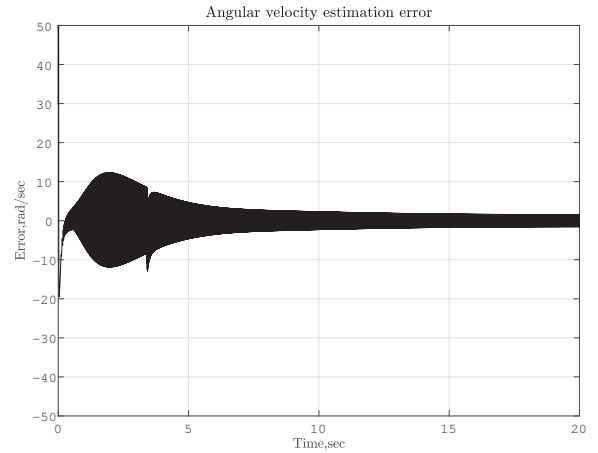

Fig. 8. Graph of the estimation error of velocity with load moment and control through the observer

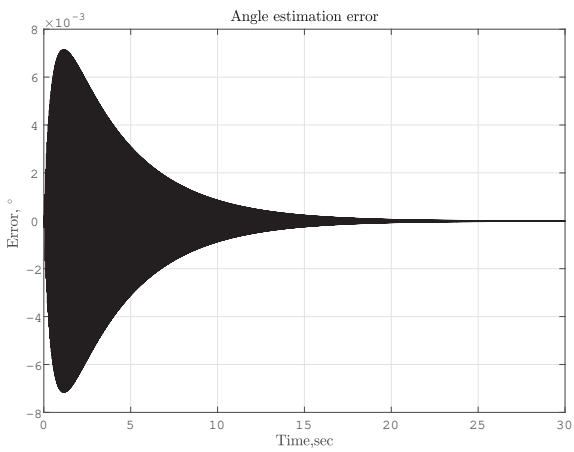

Fig. 6. Graph of the estimation error of angle without load moment and control through the observer

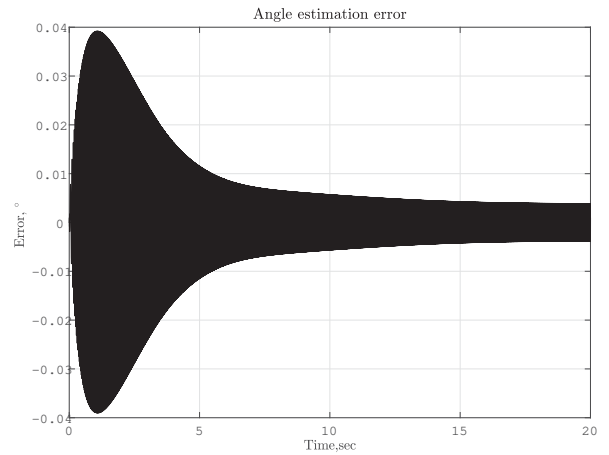

Fig. 9. Graph of the estimation error of angle with load moment and control through the observer

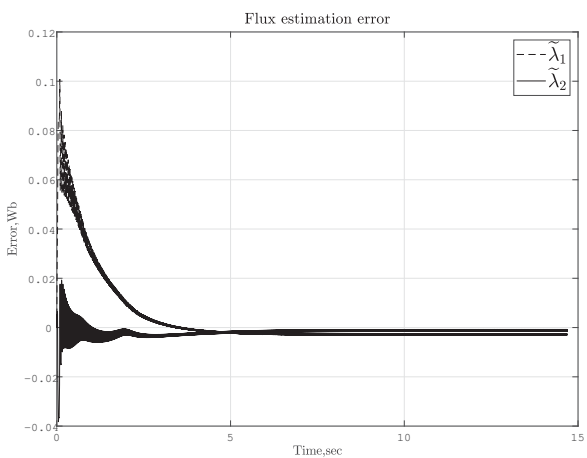

Fig. 7. Graph of the estimation error of magnetic flux with load moment and control through the observer

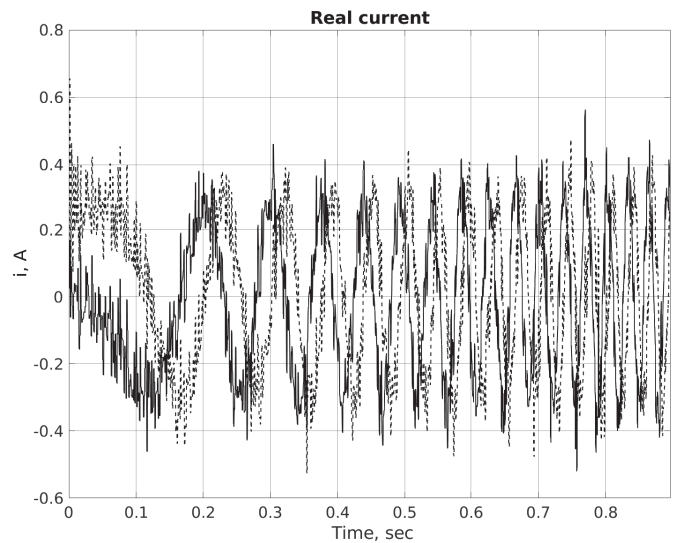

Fig. 10. Graph of the current from real motor

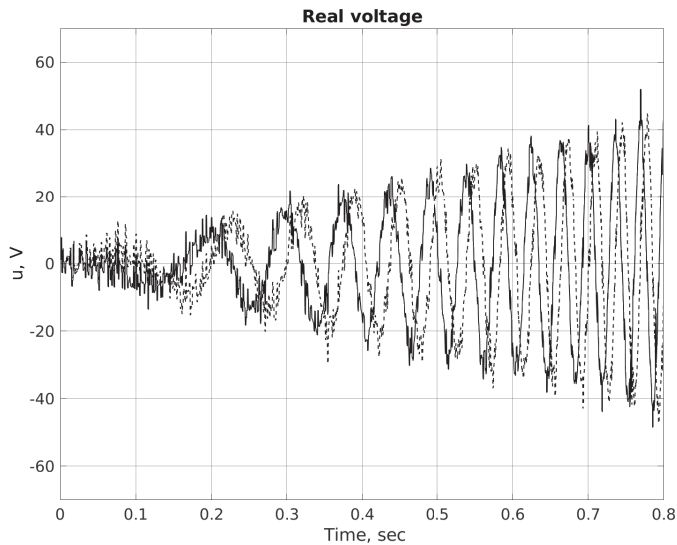

Fig. 11. Graph of the voltage from real motor

VII. FUTURE WORK

In the future, it is planned to test the performance of the algorithm on data from real motors with variety of electrical parameters and load moments, to compare new results with those obtained as a result of simulation and to analyze the advantages and disadvantages of the obtained solution in the conditions of noised signals of current and voltage.

Also problem of determining electrical parameters, that can change during motor operation, is still relevant. The proposed observer uses the assumption that the stator inductance and resistance are known and constant, which may not correspond to actual operating conditions. In this regard, there is a need to introduce observers into the control system for the estimating of these parameters.

VIII. CONCLUSION

Thus, as a result of this work, a magnetic flux observer was synthesized for a nonsalient-pole synchronous motor with permanent magnets in $\alpha\beta$ coordinates. The observer ensures robustness and convergence of the estimation error to zero. The main idea of the proposed algorithm is the consistent application of the property of the first-order filter to obtain a linear regression model based on which a nonlinear observer is synthesized.

The simulation results in the MATLAB environment demonstrate the consistency of the obtained estimation algorithm for various scenarios of motor operation, subject to the accepted assumptions regarding electrical parameters and known signals.

Also, in the simulation it was noted that by increasing the linear filtering coefficients, there is the possibility of increasing the convergence rate of the estimation error to zero, which can be useful for real motor control systems.

An important advantage of the proposed method for obtaining a regression model is the freedom from necessity of integration of known currents and voltages signals, which is used in many other magnetic flux observers for PMSMs. Since

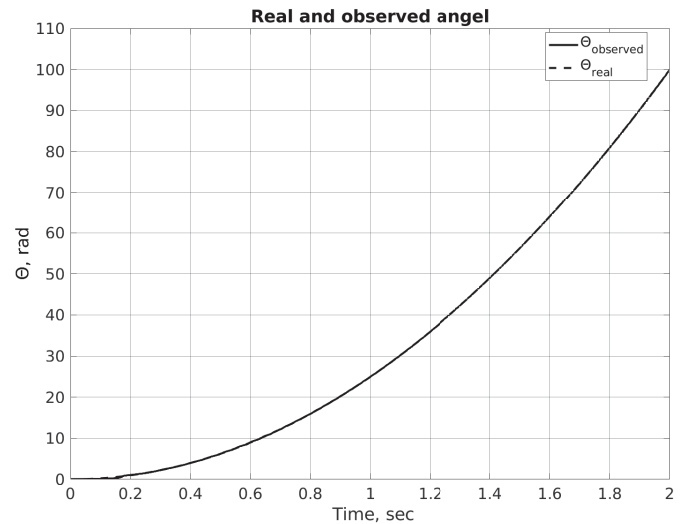

Fig. 12. Graph of the real and estimated angle

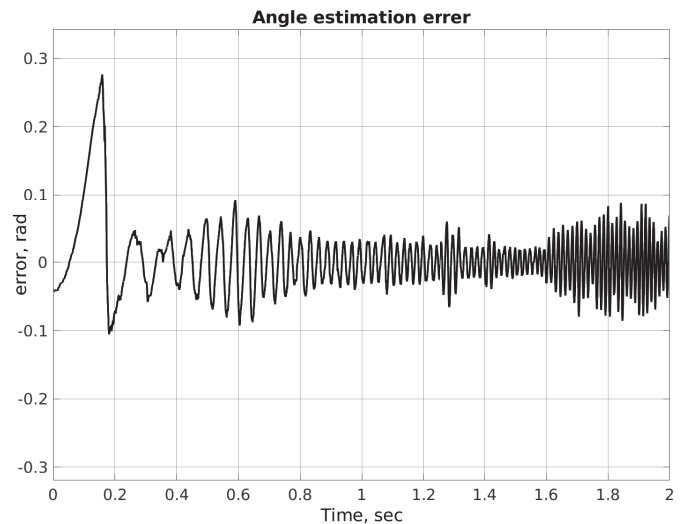

Fig. 13. Graph of the estimation error of angle

in real motors these signals are noised and have biases, the presence of an integral leads to the accumulation of errors in their measurement. The proposed algorithm successfully copes with this problem, which increases the accuracy compared to the considered analogues.

REFERENCES

- [1] I. Alsofyani and N. R. N. Idris, "A review on sensorless techniques for sustainable reliability and efficient variable frequency drives of induction motors," *J. Renewable and Sustainable Energy Reviews*, vol. 24, pp. 111–121, 2013.
- [2] R. Bojoi, M. Pastorelli, J. Bottomley, P. Giangrande, and C. Gerada, "Sensorless control of pm motor drives – a technology status review," in *2013 IEEE Workshop on Electrical Machines Design, Control and Diagnosis (WEMDCD)*. IEEE, 2013, pp. 168–182.
- [3] G. Zhang, G. Wang, and D. Xu, "Saliency-based position sensorless control methods for pmsm drives-a review," *Chinese Journal of Electrical Engineering*, vol. 3, no. 2, pp. 14–23, 2017.

- [4] S. Aranovskiy, A. Bobtsov, R. Ortega, and A. Pyrkin, "Performance enhancement of parameter estimators via dynamic regressor extension and mixing," *IEEE Transactions on Automatic Control*, vol. 62, no. 7, pp. 3546–3550, 2016.
- [5] D. Bazylev, A. Pyrkin, and A. Bobtsov, "Position and speed observer for pmsm with unknown stator resistance," in *2018 European Control Conference (ECC)*. IEEE, 2018, pp. 1613–1618.
- [6] R. Ortega, L. Praly, A. Astolfi, J. Lee, and K. Nam, "Estimation of rotor position and speed of permanent magnet synchronous motors with guaranteed stability," *IEEE Transactions on Control Systems Technology*, vol. 19, no. 3, pp. 601–614, 2010.
- [7] P. Bernard and L. Praly, "Robustness of rotor position observer for permanent magnet synchronous motors with unknown magnet flux," *IFAC-PapersOnLine*, vol. 50, no. 1, pp. 15 403–15 408, 2017.
- [8] B. Weber, K. Wiedmann, and A. Mertens, "Increased signal-to-noise ratio of sensorless control using current oversampling," in *2015 9th International Conference on Power Electronics and ECCE Asia (ICPE-ECCE Asia)*. IEEE, 2015, pp. 1129–1134.
- [9] A. S. Mohamed, M. S. Zaky, A. El Din, and H. A. Yasin, "Comparative study of sensorless control methods of pmsm drives," *Innovative Systems Design and Engineering*, vol. 2, no. 5, pp. 44–66, 2011.
- [10] A. T. Nguyen, M. S. Rifaq, H. H. Choi, and J.-W. Jung, "A model reference adaptive control based speed controller for a surface-mounted permanent magnet synchronous motor drive," *IEEE Transactions on Industrial Electronics*, vol. 65, no. 12, pp. 9399–9409, 2018.
- [11] V. Y. Frolov and R. I. Zhiligitov, "Development of sensorless vector control system for permanent magnet synchronous motor in matlab simulink," *Journal of Mining institute*, vol. 229, pp. 92–97, 2018.
- [12] D. Bazylev, A. Pyrkin, and A. Bobtsov, "Algorithm for adaptive sensorless control of synchronous motors," *Scientific and Technical Journal of Information Technologies, Mechanics and Optics*, vol. 18, no. 1, pp. 24–31, 2018, (in Russian).
- [13] A. Bobtsov, A. Pyrkin, and R. Ortega, "A new approach for estimation of electrical parameters and flux observation of permanent magnet synchronous motors," *International Journal of Adaptive Control and Signal Processing*, vol. 30, no. 8-10, pp. 1434–1448, 2016.
- [14] S. Sastry and M. Bodson, *Adaptive control: stability, convergence and robustness*. NY: Dover Publications, 1989.
- [15] M. Marchesoni, M. Passalacqua, L. Vaccaro, M. Calvini, and M. Venturini, "Performance improvement in a sensorless surface-mounted pmsm drive based on rotor flux observer," *Control Engineering Practice*, vol. 96, p. 104276, 2020.